



*An Online PDH Course
brought to you by
CEDengineering.com*

Introduction to Pretreatment Considerations for Water Desalination

Course No: H02-006

Credit: 2 PDH

J. Paul Guyer, P.E., R.A., Fellow ASCE, Fellow AEI



Continuing Education and Development, Inc.

P: (877) 322-5800

info@cedengineering.com

www.cedengineering.com

This course is adapted from the Unified Facilities Criteria of the United States government, which is in the public domain, has unlimited distribution and is not copyrighted.

CONTENTS

- 1. SITE SELECTION**
- 2. WATER SOURCE SELECTION**
- 3. GENERAL PROCESS SELECTION**
- 4. PRETREATMENT CONSIDERATIONS**

1. SITE SELECTION

1.1 SITE TECHNICAL REQUIREMENTS. Site technical requirements are specific to each particular process. Generalized recommendations can be made regarding location, space, and access requirements. A typical desalination system flowsheet is shown in Figure 3-1. A typical desalination system layout, using reverse osmosis as a sample process, is shown in Figure 3-2.

1.1.1 LOCATION. Desalination facilities will be located as close to the raw water source as possible in order to avoid excessive pipeline or pumping costs and to minimize operation and maintenance costs for pumping raw water (high saline content). Topography should be considered in the siting of a desalination facility, and gravity flow should be used where possible.

1.1.2 SPACE REQUIREMENTS. The space required for desalination facilities is determined by the process. Membrane desalination equipment needs less space than distillation/condensation desalination equipment. In general, space requirements are less for the desalination equipment than for a conventional surface water treatment plant of the same capacity. An exception is solar desalination systems. These systems employ solar collectors that require an area several times greater than other types of desalination equipment in order to achieve equal capacity.

1.1.3 ACCESS. Access to systems must be provided to permit routine maintenance, sludge and brine removal, and delivery of desalination equipment and supplies. The access requirements for desalination facilities are similar to those for conventional water treatment facilities.

1.2 WATER STORAGE AND SYSTEM MODULARIZATION.

1.2.1 EQUIPMENT DOWNTIME. In all distillation/condensation and many membrane desalination plants, storage will be determined by equipment downtime when equipment

downtime is more than 1 day. To determine the necessary storage, establish the longest period of time that could be required for planned or unplanned maintenance. Calculate the storage by multiplying this time period by the water demand rate.

1.2.2 PEAK DAILY DEMANDS. When maximum equipment downtime is less than 1 day, the peak daily demands may set a larger storage demand.

1.2.3 FIRE WATER STORAGE. On a facility served by a desalination system, fire water may be saline water or potable water depending on economic analysis. Dual water distribution system will be required if saline water is used. Hence, part of the fire protection water can be either saline or potable water due to piping and pumping cost. Economic evaluation of various design alternatives is usually needed to assure the optimal design to be adopted.

1.2.4 SYSTEM REDUNDANCY AND MODULARIZATION. One complete and functional desalination module in excess of that required to supply the design flow will be provided as redundant capacity, and all desalination systems will have a minimum of three independently functioning desalination modules where practicable.

2. WATER SOURCE SELECTION

2.1 GENERAL. The selection of a water supply will be based on available quantity, quality, and cost of development. Investigate usable fresh surface water and groundwater thoroughly, prior to consideration of sources requiring desalination. When fresh water sources do not exist, consider saline water sources. The most commonly used parameter to differentiate between saline water qualities is total dissolved solids (TDS). The total dissolved solid is defined as the sum of the dissolved organic materials and the inorganic salts. Fresh waters contain less than 1,000 milligrams per liter of total dissolved solids. Brackish water contains 1,000-20,000 milligrams per liter of total dissolved solids. Sea water usually contains at least 20,000 milligrams per liter of total dissolved solids. Quantities of potable water needed will be determined by an analysis of the site.

2.2 QUALITY. The quality will be determined by the planned use. Physical, chemical, and

bacteriological testing of source waters are required to determine the level of treatment to supply the necessary water quality. When the quantity withdrawn exceeds the recharge rate, quality inherently decreases; therefore, this must be considered during design.

2.2.1 PHYSICAL CHARACTERISTICS. The physical characteristics of the raw water source that must be evaluated are total suspended solids (TSS), temperature, turbidity and silt density index (SDI).

2.2.1.1 TOTAL SUSPENDED SOLIDS. The total suspended solids level of raw water sources must be evaluated to determine the level of pretreatment processes required. Raw water having low total suspended solids levels generally requires less pretreatment. The source with the lowest total suspended solids is preferred.

2.2.1.2 TEMPERATURE. The temperature of the raw water source must be matched to the specific desalination process. In extreme cases, the water temperature may control the desalination process selection. A climatological survey must be made prior to finalization of process selection to determine the seasonal maximum and minimum water temperatures of the proposed water sources.

2.2.1.3 TURBIDITY AND SILT DENSITY INDEX. These two characteristics provide two different measures of the amount of fine particulate matter in the water. Turbidity is measured in nephelometric turbidity units (a measure of the amount of light scattered by a known water sample thickness). Silt density index is a measure of the amount of 0.45-micron filter plugging caused by passing a sample of water through the filter for 15 minutes. Turbidity must be determined for all desalination processes. Also, the silt density index must be determined for water being considered for reverse osmosis treatment.

2.2.2 CHEMICAL CONSTITUENTS. The chemical constituents of the raw water must be determined to provide information for treatment selection. Table 2-1 shows the water testing analyses required for desalination treatment.

WATER TESTING REQUIRED FOR DESALINATION TREATMENT

TEST	PROCESS		
	Electrodialysis Reversal	Reverse Osmosis	Distillation
TDS	O-P	O-P	D-P
Temperature	O	O	D
Turbidity	O-P	O-P	D-P
Suspended Solids	P	P	P
Color	O-P	O-P	D-P
Corrosivity	O	O	D
Odor	P	P	P
pH	O-P	O-P	D-P
Alkalinity	O-P	O-P	D-P
Total Hardness	O-P	O-P	D-P
Noncarbonate Hardness	O-P	O-P	D-P
Carbonate Hardness	O-P	O-P	D-P
H2S	O	O	D
Chlorine Demand	O	O	D
Bacterial Contamination	O-P	O-P	D-P
Plankton	O	O	D
Oil and Grease	O	O	D
Endrin	O-P	O-P	D-P
Lindane	O-P	O-P	D-P
Methoxychlor	O-P	O-P	D-P
Toxaphene	O-P	O-P	D-P
2, 4-D	O-P	O-P	D-P
2, 4, 5-TP Silvex	O-P	O-P	D-P
Trihalomethanes	P	P	P
Ammonia	O-P	O-P	D-P
Arsenic	O-P	O-P	D-P
Barium	O-P	O-P	D-P
Cadmium	O-P	O-P	D-P
Chromium	O-P	O-P	D-P
Lead	O-P	O-P	D-P
Mercury	O-P	O-P	D-P
Nitrate	O-P	O-P	D-P
Selenium	O-P	O-P	D-P
Silver	O-P	O-P	D-P
Fluoride	O-P	O-P	D-P
Zinc	O-P	O-P	D-P
Copper	O-P	O-P	D-P
Boron	O-P	O-P	D-P
Calcium	O-P	O-P	D-P
Magnesium	O	O	D
Strontium	O	O	D
Sodium	O	O	D
Potassium	O	O	D
Bicarbonate	O	O	D
Carbonate	O	O	D
Sulfate	O-P	O-P	D-P
Chloride	O-P	O-P	D-P
Iron	O-P	O-P	D-P
Manganese	OP	O-P	D-P
Molybdenum Reactive			
Silica		O	
Molybdenum Nonreactive			
Silica		O	
Silt Density Index		O	

Legend:

- D = Required for desalination process design
- P = Required for potable water design

Table 2-1

Water Testing Required for Desalination Treatment

2.2.3 BACTERIOLOGICAL QUALITY. The bacteriological testing of the raw water must include a type of a coliform indicator organism count. For procedures for filter membrane,

most probable number fermentation tube, and standard plate count, coliform organism bacteriological testing techniques can be found in the professional literature. Manufacturers' recommendations as to the media and procedures used to identify microbiological activity detrimental to the operation of a particular desalination system shall be followed.

2.3 SELECTION VERSUS REJECTION OF POTENTIAL RAW WATER SOURCES. After the completion of physical, chemical, and bacteriological testing, a final water source may be selected. Extreme care must be taken in the selection of a source where the usage rate is greater than the recharge rate. In most cases, selection will involve choosing the brackish water with the lowest level of total dissolved solids. When brackish water is not available, use sea water or water as the feed water source. When the coliform indicator organism count of a water is greater than 10,000 most probable number (MPN), then the water source should be rejected for sanitary reasons and a more saline water chosen (per Standard Methods for the Examination of Water and Wastewater). If other water is available, water containing more than 1,000 nephelometric turbidity units should be rejected on the basis of the high cost and difficulty of clarification, even if the alternative water is more saline. When the total delivery pumping pressure of less saline water is greater than the operating pressure of a reverse osmosis system, then the desalination of the more saline water by reverse osmosis may be more economical than the combined cost of delivery and desalination of the less saline source. The final selection of a raw water source will be based on economic studies. In some cases, the decision cannot be made until all systems are fully designed and life cycle costed.

3. GENERAL PROCESS SELECTION

In selecting a potable water production system, it is important to estimate costs of various options. The conventional unit of comparison is cost in dollars per 1,000 gallons of product water. Water quality and energy sources will be estimated from simple site reconnaissance. For example, a sea coast site where the water source temperature exceeds 95 degrees Fahrenheit, indicates a high-salinity high-temperature combination favoring distillation/condensation processes. Reverse osmosis requires a feed water temperature below 95 degrees Fahrenheit. If local well testing indicates salinity between 500 and 3,000 milligrams per liter and electricity is inexpensive, electrodialysis reversal or highflux reverse osmosis is

indicated.

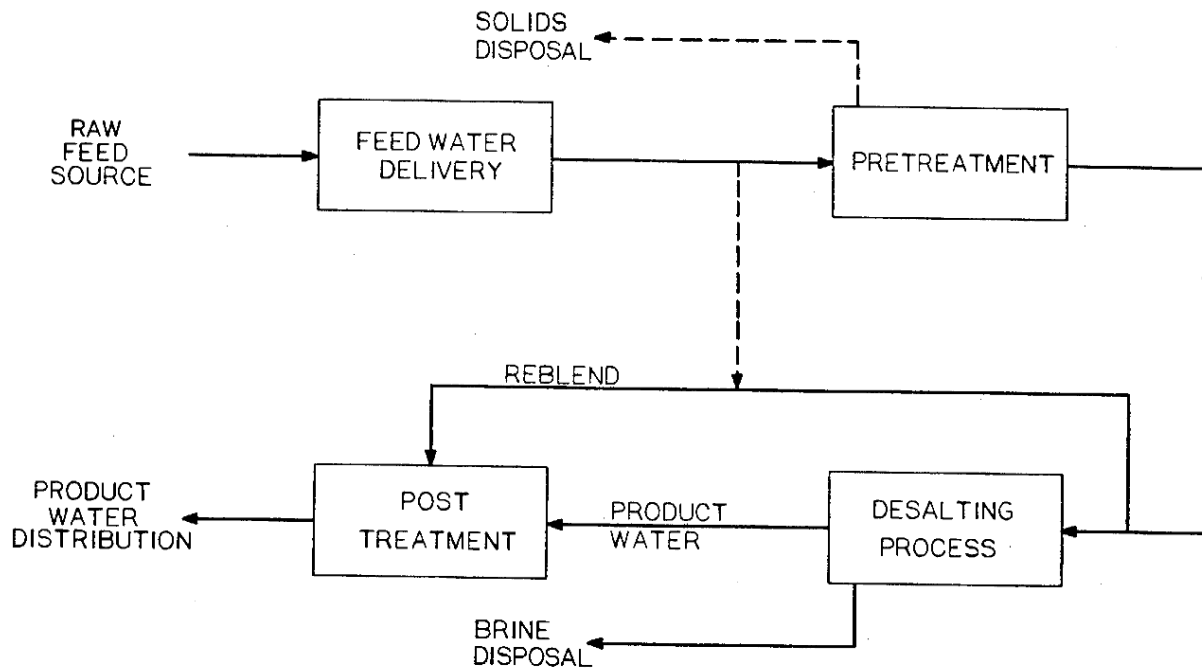

Figure 3-1

Typical desalination flowsheet

3.1 DESALINATION REQUIREMENTS. The design of a desalination system requires a clear understanding of the following: the quantity of product water desired; the quality of the desired product; and the quality of the feed water source. This course addresses the production of potable water containing less than 500 milligrams per liter of total dissolved solids. Laundries, boilers, mess halls, and hospitals may require water purer than 500 milligrams per liter of total dissolved solids. Potable water from the desalination system may be further treated to meet these requirements.

3.2 SALINE FEED WATER QUANTITY. The production of potable water from saline water usually requires a significantly larger quantity of saline feed water than the quantity of potable water produced. When desalination is necessary to produce potable water, the process splits the feed water into two streams. One stream is the product water; the other stream is the brine that contains most of the salts originally in the feed water. In waters that need very little

desalination, high-rate reverse osmosis may only reject 5 percent of the feed stream as brine. In reverse osmosis of sea water, more than 70 percent of the intake water may be rejected as brine. Multiply the required product quantity by the reciprocal of the product water recovery fraction to find the quantity of saline water that must be processed to yield the desired quantity of product water. In equation form it can be expressed as:

$$100\% \text{ recovery of product water} \times \text{water demand} = \text{saline feed water flow}$$

In some cases, the limited quantity of available saline water may require a decision to adopt a more expensive desalination process with a higher water recovery rate. However, it may require choosing different and more saline feed water with a greater availability.

3.3 BLENDING OF WATERS. Blending a high concentration stream with a low concentration stream, wastes the osmotic pressure energy between the two streams. Therefore, it is best to match the design of the desalination system to the product quality desired. When a desalination process cannot be economically matched to the desired product quality, then a process that yields water with a very low dissolved material content must be used. To conserve capital and equipment costs and meet the desired water demand, the high purity product water can be blended with the pretreated saline feed water to produce the required product quantity and quality. The following equation can be used to calculate the concentration of a blended water stream:

$$\left(\sum_{i=1}^{i=n} \text{concentration } i \times \text{flow } i \right) / \text{total flow} = \text{blended concentration}$$

When only two streams are blended, the equation can be rearranged to show the flow of concentrated water that when blended with a dilute flow will result in the desired product concentration. This rearranged equation is as follows:

$$[(P - H)(D)] / (C - P) = F$$

Where:

P = Desired product water concentration

H = High purity water concentration

D = Flow of the high purity water

C = Concentration in the impure concentrated stream

F = Flow rate of the concentrated stream

The same blend equations will apply to blending for remineralization, which is a more common procedure.

3.4 PROCESS LIMITATIONS. The various desalination processes presently available have limitations that must be considered prior to selecting a desalination process for a particular site. These limitations apply only to the desalination processes themselves; pretreatment can be and is often used to bring saline feed water within limits so that a desalination process can be used. The raw feed water chemistry for all desalination systems must be evaluated thoroughly for constituents that may precipitate in the desalination system.

3.4.1 HIGH-TEMPERATURE DISTILLATION. High-temperature distillation is limited by the saturation of alkaline earth metal salts, such as CaSO_4 , BaSO_4 , SrSO_4 , CaCO_3 , BaCO_3 , and SrCO_3 . Carbonate salt scaling can be controlled by acid addition. The recovery of water from a high-temperature distillation plant is usually limited by calcium sulfate solubility. When the concentration of the sulfate and the limiting alkaline earth metal is one-third of the saturated condition at ambient temperature, distillation design must include pretreatment to reduce or inhibit the scaling ions. High-temperature distillation is also limited to oil and grease levels below 1 milligram per liter. All other limitations on the high-temperature distillation process are equipment specific and require individual evaluation.

3.4.2 LOW-TEMPERATURE AND MECHANICAL DISTILLATION. Low-temperature and mechanical distillation systems are limited to operation below saturation of alkaline earth sulfates and carbonates. The lower operating temperature permits economical operation on waters that are at or below half saturation at ambient temperature. Oil and grease are limited to less than 1 milligram per liter. Any other limitations are equipment specific.

3.4.3 REVERSE OSMOSIS. The most severe limitation on reverse osmosis is the maximum limit of 50,000 milligrams per liter of total dissolved solids in the feed water. Another limitation is that there must be no iron in the feed water. This limitation is so rigid that only stainless steel and non-ferric materials will be used downstream of the iron removal. The solubility of alkaline earth sulfates and carbonates limits reverse osmosis treatment. Any water containing less than 4,000 milligrams per liter of total dissolved solids that would be saturated with an alkaline earth sulfate when the concentration is multiplied by 1.5 should not be considered for reverse osmosis desalination. Reverse osmosis is limited to waters that do not have silica saturation in the reject brine. Silica chemistry is extremely complex. When the molybdenum reactive silica concentration exceeds 30 milligrams per liter as SiO₂ or the pH exceeds 8.3 in the brine stream, an environmental chemist or engineer should be consulted. Reverse osmosis is also limited to the treatment of waters with less than 1 milligram per liter of oil and grease.

3.4.3.1 CELLULOSE ACETATE MEMBRANES. Cellulose acetate membranes are usually limited to pH levels between 4.0 and 7.5. Cellulose acetate membranes require some form of continuous disinfection with the feed water to prevent microbial degradation of the membranes and can tolerate up to 1 milligram per liter of free chlorine. Therefore, cellulose acetate membranes are usually disinfected by maintaining 0.2 to 0.9 milligrams per liter of free chlorine in the feed water. Cellulose acetate membranes cannot be used on waters where the temperature exceeds 88 degrees Fahrenheit. Cellulose acetate membranes should not be used at pressures greater than the manufacturer's recommended pressure, since they are prone to membrane degradation by pressure compaction.

3.4.3.2 POLYAROMATIC AMIDE MEMBRANES. Brackish water polyaromatic amide membranes are generally limited to operation in feed waters between pH 4 and pH 11. Polyaromatic amide membranes are less pH tolerant and should not be used outside of the range pH 5 to pH 9. All polyaromatic amide membranes are limited to use on feed streams that are free of residual chlorine. If chlorination is necessary or desirable as a pretreatment option, complete dechlorination must be effected. Polyaromatic amide membranes are tolerant of water temperatures up to 95 degrees Fahrenheit. While polyaromatic amide membranes are not as quickly or completely compacted as are cellulose acetate membranes, manufacturer's recommended pressures must be followed to prevent mechanical damage to membrane modules.

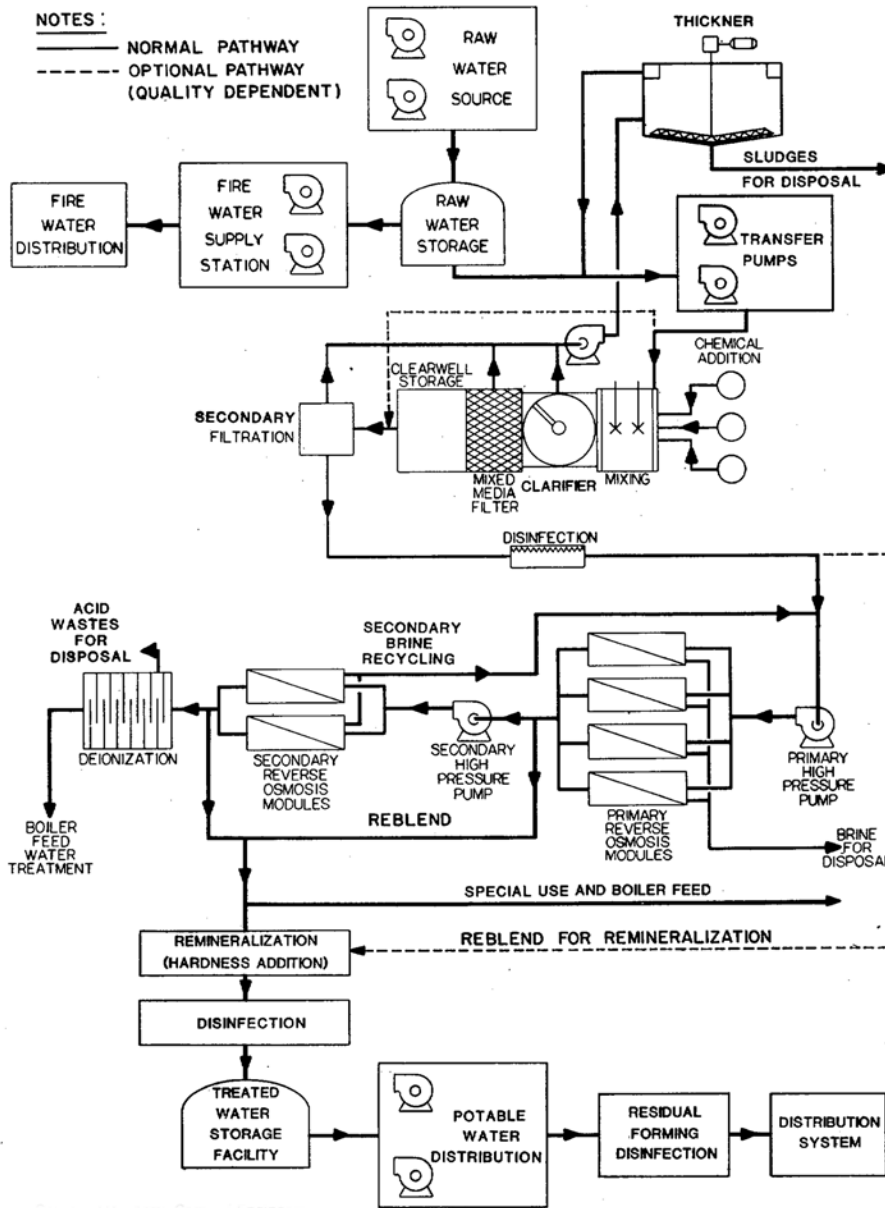

Figure 3-2

Typical reverse osmosis desalination system

3.4.3 ELECTRODIALYSIS REVERSAL. While electro dialysis reversal has been used to treat water as saline as sea water, 4,000 milligrams per liter of total dissolved solids is considered to be an upper limit for economical operation. Some electro dialysis membranes can tolerate strong oxidants, like chlorine, but most cannot. The reversal of polarity used in electro dialysis reversal for removal of scale allows operation on water that is saturated with

alkaline earth carbonates. Saturation with an alkaline sulfate with low carbonate alkalinity should be avoided.

3.3 DISTILLATION/CONDENSATION ENERGY. In distillation/condensation plants, energy is used in the form of steam and electricity. Steam is used to heat the saline water to increase its vapor pressure. Normally, electricity is used to run the compressor in vapor compression distillation. If excess steam is available, its use as a power source should be investigated.

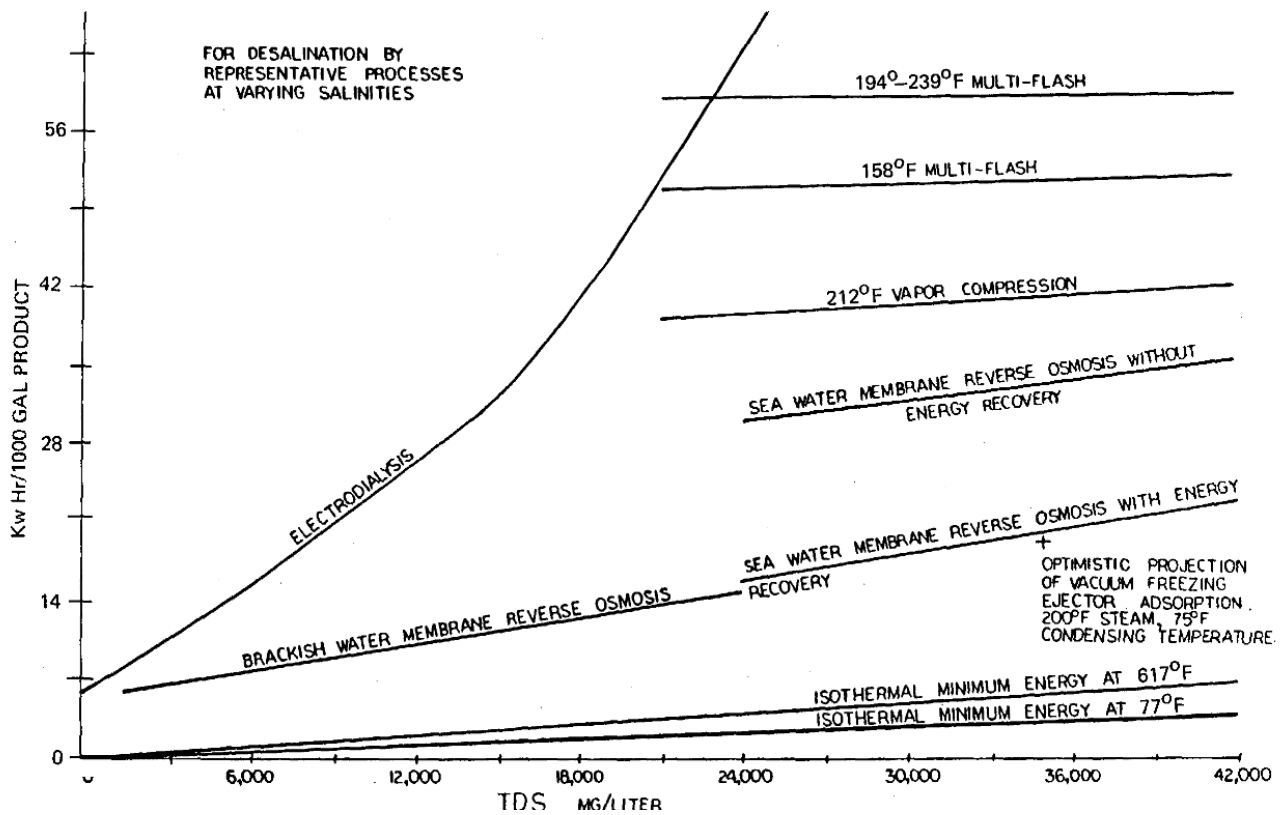

Figure 3-3
Energy Consumption

The amount of electricity or mechanical work that steam will yield depends on its temperature as well as the temperature to which it can be condensed. The energy consumption of both vapor compression and thermal distillation, as related to the total dissolved solids of feed water, is shown in Figure 3-3.

RULE	A	B	C	D	D	E
	If the freshest source of water is:	And if the desired output water will be:	And if electricity is to be generated:	And if the projected cost ratio of 264 deg F steam/ electricity:	Then investigate the cost of:	And have the following tests performed:
1	More salty than sea water	Potable water			Transportation of fresher water; distillation can be used but at great expense	Total Dissolved Solids (TDS)
2	Sea water	High-pressure boiler feed water	By steam turbine		Distillation followed by ion exchange	TDS, Ca, SO ₄ , CO ₃ , pH
3	Sea water	Potable water	By steam turbine	Greater than 10 ⁷ BTU/kwh	Thermal distillation either with or without vapor compression	TDS, Ca, SO ₄ , CO ₃ , pH
4	Sea water	Potable water	By internal combustion engine		Vapor compression distillation and waste heat	TDS, bacterial count, turbidity
5	Sea water	Potable water	no	Less than 10 ⁷ BTU/kwh	Reverse osmosis	TDS, Ca, SO ₄ , CO ₃ , pH, bacterial count, silt density index, turbidity, oil & grease
6	Brackish water	Potable water			Reverse osmosis	TDS, Ca, SO ₄ , CO ₃ , pH, bacterial count, silt density index, turbidity, oil & grease
7	Slightly saline brackish water	Potable water			Electrodialysis reversal	TDS, full ionic breakdown, bacterial count, turbidity

Table 3-1
Preliminary desalination process selection

3.4 MEMBRANE ENERGY. Historically, membrane desalination systems use less energy than other systems. Brackish water desalination should be accomplished by membrane separation processes because of the reduced energy requirement. The energy consumption of electrodialysis reversal can be made to follow reduced or variable salinity, while the energy consumption of reverse osmosis is set principally by membrane water flux. Again, the energy consumption of electrodialysis reversal and reverse osmosis as a function of the total dissolved solids content of the feed water is shown in Figure 3-3. As membrane materials are developed, energy consumption may be reduced.

3.5 WASTE DISPOSAL. Waste disposal may influence process selection. Since brine disposal costs can be an important part of process economics, brine disposal alternatives must be explored while water quality analyses are being performed.

3.6 PRELIMINARY PROCESS SELECTION. Use preliminary site information to eliminate certain desalination processes. A decision logic table for use with preliminary information is shown in Table 3-1. Decisions based upon Table 3-1 are to be considered preliminary only. Necessary water quality tests to further support the recommendations made in Column E of Table 3-1 are in Column F.

3.7 PROCESS SELECTION. When initial site and raw water source selections have been made, use preliminary water quality information with Table 3-1 to assist in a preliminary process selection. As more specific information is obtained from laboratory analyses of water quality, make an initial process selection using the second decision logic table (Table 3-2). After a treatability investigation has been completed, select the final desalination process. While the use of the decision logic table sequence will only provide generalized assistance in process selection; additional economic, engineering, and environmental studies may indicate that methods or combinations of methods must be used.

Rule	A	B	C	D	E	F
	If the feedwater TDS is (mg/liter):	And if the raw feed water suspended solids are:	And if the product of $(Ca)(SO_4)$ moles /liter in the reject brine is:	And if the oil and grease in the raw feedwater is:	Then investigate the cost of:	And have the following pretreatment processes investigated for effectiveness:
1	Greater than 50,000				Transportation of fresher water. Distillation of this water is extremely expensive.	Precipitation of less soluble salts
2	Between 20,000 and 50,000	Over 20 NTU	Considerably less than 2×10^4	Greater than 10 mg/liter	Reverse osmosis or distillation and steam and electricity	Alum jar tests, pH adjustment, 10 micron or smaller filter plugging
3	Between 20,000 and 50,000	Over 1 NTU		Less than 10 mg/liter	Reverse osmosis	Alum jar tests, 10 micron or smaller filter plugging, UV sterilization
4	Between 20,000 and 50,000	Less than 1 NTU; SDI greater than 3		Less than 10 mg/liter	Spiral-wound membrane reverse osmosis	pH adjustment, UV sterilization, chlorine disinfection, chlorine residual
5	Between 20,000 and 50,000	SDI under 3		Less than 10 mg/liter	Hollow fine-fiber membrane reverse osmosis	10 micron or smaller filter test; UV sterilization
6	Between 3,000 and 20,000	Over 1,000 mg/liter	Considerably less than 2×10^4	Greater than 10 mg/liter	Distillation	pH adjustment, alum jar test
7	Between 3,000 and 20,000			Less than 10 mg/liter	Reverse osmosis	pH adjustment, alum jar test, silt density index, UV sterilization
8	Between 500 and 4,000				Electrodialysis reversal	pH adjustment, alum jar test, 10 micron filter plugging, chlorine disinfection

Table 3-2

Selecting desalination processes after water quality data are obtained

4. PRETREATMENT CONSIDERATIONS

4.1 GENERAL. Before raw water is desalinated, the undesirable materials will be removed or reduced to acceptable levels. Such materials to be removed include solids, immiscible liquids, and sparingly soluble salts. Accumulations of these materials on desalination process surfaces greatly reduce efficiencies. Without adequate pretreatment, desalination facilities are destined for reduced lifetimes, shortened periods of operation, and high maintenance. The feedwater limitations for various desalination processes are summarized in Table 4-1. An overview of typical pretreatment options is shown in Figure 4-1.

4.1.1 SOLIDS. Physical and chemical treatment processes will be used to remove solid materials. The level of solids removal will depend on the desalination process to be used.

4.1.1.1 SETTLEABLE SOLIDS. Settleable solids are easily removed from water by gravity settling or filtration.

4.1.1.2 NON-SETTLEABLE SOLIDS. Non-settleable solids are removed by chemical treatment. Chemical treatment may be designed to remove not only nonsettleable solids but to precipitate and remove scaleforming solids.

4.1.2 IMMISCIBLE LIQUIDS. Emulsified oil and grease are the principle sources of immiscible liquid fouling in desalination facilities. Use gravity settling and chemical treatment processes followed by a filtration system to maintain immiscible liquid concentrations within acceptable levels. To measure low levels of oil and grease, a sophisticated concentration procedure must be performed.

4.1.3 DISSOLVED ORGANIC CONTAMINANTS. The most common organic materials, tannins and humic acids, can be removed from water by chemical treatment. Some organic materials will carry across a distillation/condensation process with the water. Pesticides and industrial organic chemicals may be difficult to remove by distillation/condensation. Reverse osmosis will usually remove the majority of the large pesticide molecules. If during pretreatment tests a non-ionized organic contaminate is not reduced to acceptable levels, then a full treatability investigation will be performed to ensure that potable water standards are met.

4.1.4 SPARINGLY SOLUBLE SALTS. As physical and chemical conditions change during desalination, some soluble materials become insoluble (precipitate). This precipitation of solid materials can foul desalination systems through the formation of scale. Materials that precipitate easily to form scale are double-charged positive ions, such as calcium and magnesium salts. As water volume is reduced, the concentration of all ions and materials is increased. When the concentration reaches saturation, scale is formed. With alkaline earth sulfates and carbonates, the saturation concentration is reduced by increasing temperature. Ion exchange as well as chemical treatment followed by filtration can reduce the levels of

sparingly soluble salts before desalination processes. However, since such a treatment system may not be cost effective, economic evaluation is needed before proceeding with detailed design. Data on the concentration factor limits for calcium sulfates in sea water are available from the American Institute of Chemical Engineers.

4.2 CHEMICAL TREATMENT. Many materials, e.g., calcium salts, magnesium salts, oil and grease, total suspended solids and some organic contaminants, that are harmful to desalination processes can be reduced to acceptable levels by chemical treatment. Chemical treatment may involve any of the following: coagulation, either with or without clarification; pH adjustment, which may influence fluoride removal; or scale inhibition. When required, degasification and secondary filtration follow chemical treatment.

4.2.1 COAGULATION. Non-settleable solids and some suspended materials do not precipitate because of electrical charges on the surface of the particles. If the charges on the particles can be reduced, the particles may precipitate. Chemicals that lower surface charges are lime, alum, ferric salts, and polyelectrolytes. Evaluate each chemical used in pretreatment to determine its effect on the successive steps in the desalination process. For example, calcium present in lime can cause an increase in scale formation in distillation/condensation processes; the iron present in ferric salts can cause excessive fouling in membrane desalination systems; and alum is usually the best coagulant for desalination systems. (Do not use pretreatment chemicals without prior operational experience and an exhaustive actual application review). The nonsettleable solids and the suspended solids in conjunction with any added coagulants will be removed by either standard clarification techniques or direct filtration. Lime softening without adequate downstream filtration and pH adjustment will lead to suspended lime particles in the feed water. Lime softening will usually remove a significant amount of fluoride and may adjust the pH to the higher levels (above 7.0) where fluoride removal is optimized. Laboratory analysis or pilot studies shall be conducted to assure the optimal coagulation process design.

4.2.2 PH ADJUSTMENT. The pH adjustment step of pretreatment must result in the optimal pH level for the individual desalination system. After coagulants have been added, the pH is often changed significantly.

		Suspended Solids		Immiscible Liquids	Dissolved Organic Contaminants (Non-Ionic)	Springly Soluble Salts
		Settleable Solids	Non-Settleable Solids			
Reverse Osmosis	Distillation/Condensation	P R E S E N T	1.0 NTU* (Some equipment goes higher.)	1.0 mg/l as extractable oil and grease*	These must all be evaluated on a case-by-case basis.	Saturated at the last-stage temperature (See Sample Problem A-3).
	Spiral Wound		1.0 NTU* or 5 SDI*	1.0 mg/l as extractable oil and grease for all membranes*		Saturated in the brine stream (See Sample Problem A-3). Scale inhibitors, such as sodium hexametaphosphate, can be used to exceed saturation by two- or three-fold.
	Hollow Fine Fiber		1.0 NTU* or 5 SDI*			
	Polyaromatic Amide		3.0 SDI*			
	Cellulose Acetate		4.0 SDI*			
	Electrodialysis Reversal		Less than 10 microns*	Twice saturation in the brine stream (See Sample Problem A-3). Scale inhibitors, such as sodium hexametaphosphate, are usually effective up to 4 times the saturation.		
Ion Exchange	1.0 NTU	No oil and grease	Regeneration concentration must be adjusted, if sulfuric acid is used as regenerant.			

NOTES *Based upon manufacturer's guarantee

Table 4-1
Maximum allowable contaminants in feedwater used by various desalination processes

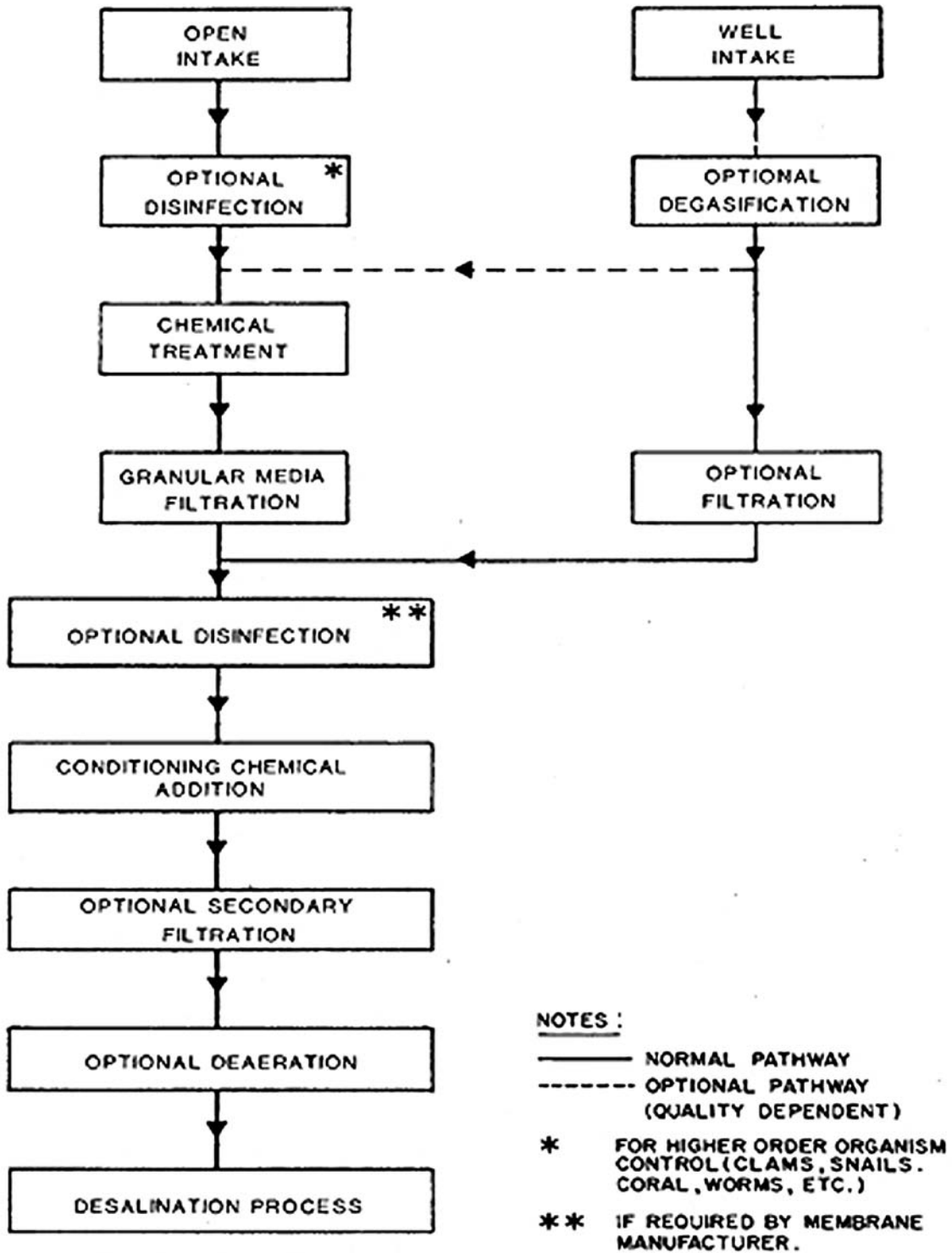

Figure 4-1
Pretreatment Techniques

In most cases, the pH must be returned to a neutral or a slightly acid level. Adjustment chemicals to lower the pH include carbon dioxide, sulfuric acid, and hydrochloric acid. Carbon dioxide should not be used for pH adjustment of lime addition systems because of the previously mentioned scaling problem associated with lime pretreatment. Sulfuric acid should not be used for pH adjustment of systems where the resulting increase in sulfate salts can cause scaling in the desalination system. Fluoride removal will be hindered, if the pH is reduced below 7.0.

4.2.3 SCALE INHIBITION. The formation of scale limits the efficiency of product water recovery during plant operation. The precipitation of calcium carbonate, magnesium hydroxide, and calcium sulfate can be prevented through the addition of scale-inhibiting chemicals. Two scale-inhibiting chemical types are commonly used: polyphosphates and polyelectrolytes. The most commonly used scale inhibitors are polyphosphate chemicals. Polyphosphates lose their effectiveness above 190 degrees Fahrenheit, which limits upper operating temperatures. To prevent the formation of scale within desalination systems, polyphosphate-based chemicals are the best general purpose additive. The most commonly used polyphosphate compound is sodium hexametaphosphate. Polyelectrolytes or organic polymers are relatively new scale inhibitors.

4.3 DEGASIFICATION AND DEAERATION. The removal of dissolved gases from feed water can be accomplished in one of two ways. The dissolved gas may be stripped out with another gas, or the dissolved gas may be stripped out with water vapor. A forced draft degasification tower will remove non-atmospheric gases. This is done by blowing air up through a tower of packing. The water to be degasified is then sprinkled over the packing. When full deaeration is required to prevent the interference of oxygen and nitrogen with water vaporization or flashing, steam or water vapor must be used as the stripping gas. On high-temperature distillation systems, a steam deaerator may be used. On most distillation desalination systems, the only economical method of deaeration of the water is to lower the pressure with a vacuum pump or venturi eductor or ejector to produce enough water vapor to strip away all dissolved gases. There are two basic designs for water distribution in deaerators. A design that sprays the water in the deaerator vessel will usually create the most

complete deaeration. The other commonly used design involves cascading the water over trays. While the internal design of this deaerator is prone to short circuiting and incomplete deaeration, it is more compact and requires no pressure to operate the sprayers.

4.4 FILTRATION WITH GRANULAR MEDIA. Before the filtration is designed, the possibility of use of wells/infiltration galleries shall be evaluated. Filtration is necessary when the desalination process requires a low level of particulate material. Primary filtration with granular media removes particulate materials left after lime, coagulants or other chemicals have been added to the feed waters. Single-or dual-media filtration systems are generally used. In some cases, mixed-media filtration may be necessary. Filters may use either pressure or gravity flow methods.

4.4.1 SINGLE-MEDIA FILTRATION. Single-media filtration consists of one media. This media is often small-grained silica sand; however, anthracite may be used after lime and lime-soda softening. Some desalination pretreatment systems use an alternate media, such as greensand, to remove iron compounds. Diatomaceous earth media is not recommended for primary filtration because of its characteristic high head loss and short run times.

4.4.2 DUAL-MEDIA FILTRATION. Dual-media filtration consists of two media with different specific gravities. The difference creates a two-layer separation effect. Use silica sand or greensand for one layer; use anthracite for the other layer. The use of dual media will allow larger quantities of material to be filtered and will reduce head loss during operation. The use of two media types will provide a good coarse-to-fine filtration process for desalination facilities.

4.4.3 MIXED-MEDIA FILTRATION. When three media are used in filters, a better coarse-to-fine filtration pattern can be constructed. High-density silica sand, garnet, and anthracite are commonly used to provide the filter bed. The different media do not stratify completely. Instead, there is a small amount of intermixing among the different layers. This gradual change in media size provides a gradient from coarse to fine and creates a media flow pattern necessary to achieve a very low silt density index.

4.5 SECONDARY FILTRATION. Secondary filtration is necessary to ensure that particulate material does not pass from the pretreatment systems into a membrane desalination process. Secondary filtration is used normally as a precautionary measure. Cartridge filters are commonly used. Ultrafiltration systems can be used as a process and precautionary measure.

4.5.1 CARTRIDGE UNITS. The necessary protection is most easily accomplished with cartridge filters. The cartridges are replaced easily, and the filter mesh can be sized to remove from 20-micron to 0.05-micron particles. Although some cartridge filters can be backwashed, most are replaced when head loss reaches excessive levels.

4.5.2 ULTRAFILTRATION UNITS. The newer process for secondary filtration is ultrafiltration. New materials provide 0.005-micron filtration in a stable, backwash operational unit. Some ultrafiltration units possess a salt-rejection capability, which reduces both the ultrafine particulate material and salt loading on membrane desalination processes. The ability to ensure particulate removal at 0.005-micron levels, as well as backwash capabilities, makes ultrafiltration an excellent secondary filtration technique.

4.6 DISINFECTION. Biological growth can seriously interfere with desalination surfaces and equipment. Cellulose acetate reverse osmosis membranes can be attacked by bacteria and require continuous disinfection application at the membrane surface. Disinfection of potable waters is required for sanitary reasons. Marine intake structures are particularly prone to biogrowths. A strong biocide is usually needed to prevent extensive marine growths from fouling intakes, piping and storage facilities. An overview of disinfection alternatives can be found in Figure 4-2. Chlorination is not advisable in the pretreatment process when organic contents are high.

4.6.1 ULTRAVIOLET IRRADIATION. One effective disinfection technique is ultraviolet irradiation. Raw waters flow through a chamber where they are exposed to ultraviolet lamps. The resulting disinfection prevents bacterial destruction of cellulose acetate-based membrane systems and eliminates bio-fouling of polyaromatic-based membrane systems.

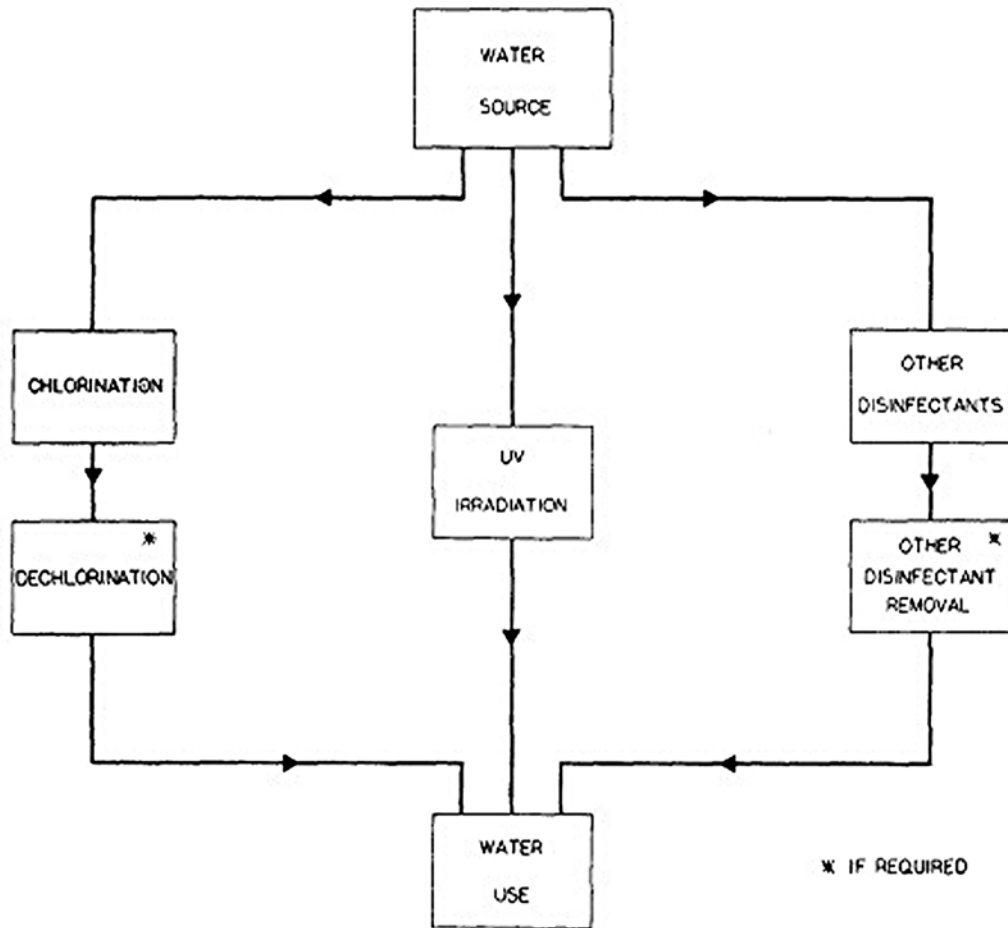

Figure 4-2
Disinfection alternatives

Because polyaromatic fiber membranes are very susceptible to chemical oxidant attack, ultraviolet disinfection is the best disinfection technique for these systems.

4.6.2 OXIDANTS. The addition of chemical oxidants, such as chlorine, bromine, iodine or ozone, can provide biological disinfection before membrane processes. The use of oxidants must be monitored carefully to keep the chlorine below 1.0 milligrams per liter of free chlorine residual that would even damage cellulose acetate membrane systems. For cellulose acetate membrane systems, a carefully monitored oxidant addition is the best technique for disinfection of biologically active feed waters. When biological and other organic materials are chlorinated, the resulting chlorine oxidation generates halogenated carbon compounds, such as the trihalomethane class of compounds. While the placement of chlorine disinfection

upstream of coagulation or filtration will increase chlorine contact time, which in turn will increase the number of organisms destroyed, it will also increase trihalomethane formation. When an open intake requires optional disinfection as shown in Figure 4-1 and chlorination is shown by pretreatment investigation to bring the trihalomethane content above 0.1 milligrams per liter, then no form of chlorine shall be used as a raw water disinfectant. The legal limit (per federal regulations) for trihalomethanes in potable water effluents for communities and installations with an effective population of 10,000 or more is 0.1 milligrams per liter.

4.6.3 DECHLORINATION. When chlorine is used as a disinfectant, complete dechlorination of pretreated waters must occur before desalination in polyaromatic membrane systems. Dechlorination can be accomplished chemically through sulfite compound addition or passage through granular-activated carbon. Complete dechlorination and destruction of the chlorine residual by reducing compounds will ensure that chemicals do not attack these sensitive membrane systems. When a chlorinated water source must be used and complete dechlorination below 1.0 milligrams per liter as free chlorine is not possible, use distillation/condensation. When dechlorination is only economically practical between 0.2 and 1.0 milligrams per liter as free chlorine, a cellulose acetate-based membrane system may be used.